

MICROSCOPE EVALUATION OF MICRO-GAPS AT IMPLANT-ABUTMENT CONNECTION

Daniel Adrian Târtea¹, Sanda Mihaela Popescu^{2*}, Horia Octavian Manolea³, Mihaela Ionescu⁴, Olimpia Marina Amărăscu^{5*}, Petre Costin Mărășescu⁶, Oana Gîngu⁷

¹PhD Student, University of Medicine and Pharmacy of Craiova, Craiova, Romania

² University of Medicine and Pharmacy of Craiova, Faculty of Dental Medicine, Department of Oral Rehabilitation, Craiova, Romania

³ University of Medicine and Pharmacy of Craiova, Faculty of Dental Medicine, Department of Dental Materials, Craiova, Romania

⁴ University of Medicine and Pharmacy of Craiova, Faculty of Dental Medicine, Department of Medical Informatics and Biostatistics, Craiova, Romania

⁵ University of Medicine and Pharmacy of Craiova, Faculty of Dental Medicine, Department of Dental Morphology, Craiova, Romania

⁶ University of Medicine and Pharmacy of Craiova, Faculty of Dental Medicine, Department of Dental Technology, Craiova, Romania

⁷ University of Craiova, Faculty of Mechanics, Department of Engineering and Management of Technological Systems, Craiova, Romania

Corresponding author: **Sanda Mihaela Popescu**; e-mail: sm_popescu@hotmail.com;
Olimpia Marina Amărăscu; e-mail: marina.amarascu@umfcv.ro;tel

ABSTRACT

The use of custom CAD/CAM abutments in implant restorations has become a reality, but there are questions about the existence of micro-gaps at the implant-abutment junction larger than those of the original standard stock abutments. **The purpose** of this study was to compare dimensions of the micro-gaps between four types of implant abutments (original dental implant stock abutments, compatible dental implant stock abutments, and two types of customized CAD/CAM dental implant abutments) all with the same connection of Bredent Sky system mounted on a standard implant. **Material and Method:** Micro-gap measurements were made on four groups of Titanium abutments: 1) original dental implant stock abutments – industrial machined, 2) compatible dental implant stock abutments – industrial machined and 3) and 4) compatible customized CAD/CAM dental implant abutments – non-industrial milled with two different parameters in hyperDENT CAM software and Paragon Tools. The Nikon SMZ745T stereomicroscope was used to measure the micro-gaps of each dental implant abutment and results were statistically analyzed. **Results:** The micro-gaps measured on implant-abutments junction did not show significant differences between original abutment, and the three types of compatible abutments. **Conclusions:** No significant differences of the micro-gap at the implant-abutment junction were observed between the original implant abutments and compatible abutments, and customized abutments. Micro-gap dimensions were within the clinically accepted limit and the use of custom CAD/CAM dental implant abutments is reliable.

Key words: dental implant custom abutments, CAD/CAM, dental technology, micro-gap, implant-abutment interface, vertical fit

INTRODUCTION

The long-term success of a dental implant is also given by a determining factor in the field of an implant system, namely the stability of the implant-abutment connection [1]. A dental implant system consists of an implant that is surgically implanted into the upper jawbone or lower jawbone and an abutment that pairs with the implant once the implant successfully integrated into the bone [2]. The

most used dental implant systems are those that use a screw to fix the prosthetic abutment to the implant, and when screwing it, the torque is very important to avoid micromovements of the prosthetic abutment, because technical problems can occur, from loosening the screw to its fracture due to excessive micromovements [3].

The efficiency of adapting the abutment to the implant depends on several factors, such as

component design, geometry of the implant-abutment connection, mechanical adjustment between the fastener and its surface fixed on the abutments, mechanical and physical properties of components and torque application [4].

Although on the market there is the external connection and the internal connection between the prosthetic abutment and the implant, the internal connection is the most used and recommended connection because it could distribute intraoral forces deeper inside the implant, protect the screws from excessive load and provide a strong and stable interface [5].

A dental rehabilitation that is fixed on multiple implants has a better load distribution with a lower concentration of tension at the prosthetic abutment-implant interface than the prosthesis with only one tooth per implant. Bending moments become more significant in single-tooth dentures, since the load distribution effect is absent [6].

Several research projects have been carried out with the intention of providing solutions for achieving a precise and stable connection between the components of implant systems, with the objective of verifying micro-gaps, micro-movements and micro-leaks between the dental implant and the prosthetic abutment [7,8,9]. According to Scarano A. et al. [7], the micro-gaps between the dental implant abutment and the implant is defined as the microscopic space between the dental implant and the corresponding prosthetic abutment. Alves D.C. et al. [8] argue that due to production limitations, the prosthetic abutment cannot adapt perfectly to the dental implant. The existence of the micro-gaps is no longer in doubt, however, there are differences between the materials used to manufacture the dental implant abutment. Hernigou P. et al. [9] observed that the micro-gaps between the titanium dental implant abutment and the dental implant is smaller than the micro-gaps between the zirconium dental implant abutment and the dental implant.

Although the manufacturing precision of the dental implant abutment and the dental implant is currently very high, however, the micro-movement between the prosthetic

abutment and the dental implant generated by mastication cannot be avoided [10], and micro-movement leads to micro-abrasion and micro-displacement between the dental implant abutment and the dental implant [11]. The size of the micro-movement generally varies between 1.52 μm and 94.00 μm [3]. Nascimento C. et al. [12] showed in their study that most of the oral bacteria were 0.2-1.5 μm wide and 2-10 μm long, while the micro-gap between the two components ranges from 0.1 μm to 10 μm . Ericson I. et al. [13] referred to micro-leakage as the passage of bacteria, toxic bacterial byproducts, and small molecules through the micro-gap between the abutment and dental implant and vice versa. Micro-leakage could cause a persistent inflammatory process, which can lead to loss of alveolar bone [14].

The purpose of this study is to evaluate the differences resulting from the mechanical manufacturing process and compare the micro-gaps between the original and non-original dental implant abutments and the dental implant. The original dental implant abutments are manufactured by the same manufacturer that produce the dental implant, and the compatible or non-original dental implant abutments, more and more present in the market, are produced by different large milling centres as certified compatible. In recent years, thanks to the advancement of CAD/CAM technology, these compatible dental implant abutments are also milled in dental laboratories that have non-industrial equipment. The complete milling of a compatible custom CAD/CAM dental implant abutment, including the geometric connection through which the dental implant abutment is fixed to the dental implant, requires a milling machine equipped to mill in Titanium, a high-performance CAM software, as well as specific milling tools.

The null hypothesis of this study was that there would be no significant micro-gaps difference at the implant-abutment junction between industrially and non-industrial produced dental implant abutments.

MATERIALS AND METHODS

This study evaluates the way in which the

dental implant connection of a prosthetic abutment is fixed to the dental implant by trying to observe the micro-gaps between the two components: implant-abutment. The type of system used was Bredent Sky from Bredent Group (Senden, Germany).

We used a Bredent Blue Sky implant with a regular platform of 5.5 mm and 20 dental implant abutments with a Bredent Sky connection with a diameter of 4 mm.

The dental implant abutments were divided into 4 study lots. The first lot included the original Bredent Sky dental implant stock abutments from the Bredent Group (Senden, Germany), the Exso type. Two examples (named OBS1 to OBS2) are presented in Figure 1a.

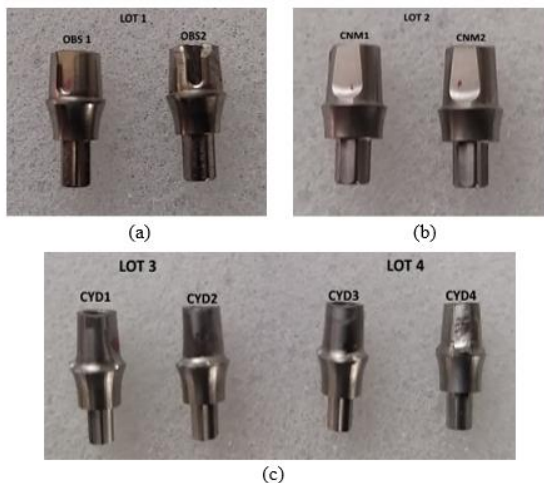

Figure 1. a) Original Bredent Sky dental implant abutments. b) Compatible Bredent Sky dental implant abutments. c) Compatible Bredent Sky dental implant CAD/CAM abutments (unchanged and modified parameters).

The second lot included five Bredent Sky compatible dental implant stock abutments from the Nova Mind company (Athens, Greece), and examples named NM1 and NM2 are presented in Figure 1b).

The third and fourth lots consisted of ten compatible custom CAD/CAM dental implant abutments milled in the dental laboratory of UGLY DENTURES SRL, Craiova, Romania, having available the Bredent Sky compatible CAD/CAM library with the 4 mm platform

from Yenadent (Istanbul, Turkey). For lot 3, we milled five compatible custom CAD/CAM dental implant abutments with unchanged parameters in the CAM hyperDENT software, and the connection was in low resolution. For lot 4, we milled five compatible custom CAD/CAM dental implant abutments with modified parameters in the CAM hyperDENT software, and the connection was in high resolution. Two examples from Lot 3 named CYD1 and CYD2, and two examples from Lot 4 named CYD3 and CYD4, are presented in Figure 1c.

For milling Bredent Sky compatible custom CAD/CAM dental implant abutments, we used the following equipment, specialized software, and materials:

Equipment:

- 5-axis milling machine with power 2.7kW Yenadent D43 (Yena, Istanbul, Turkey) (Figure 2)



Figure 2. 5-axis milling machine Yenadent D43

Software (Figure 3):

- hyperDENT Classic v9.4.3 CAM software (FOLLOW-ME! Technology Group, Munchen, Germania) (Figure 3a);
- Exocad DentalCAD v3.2 Elefsina software (Exocad GmgH, Darmstadt, Germania) (Figure 3b);
- Yenadent CAD/CAM Implant Library (Yena, Istanbul, Turcia).



Figure 3. a. hyperDENT Classic v9.4.3 b. Exocad DentalCAD v3.2 Elefsina

Materials:

- Yenadent compatible metal milling tools from Paragon Tools (Paragon Tools, Barcelona, Spain) (Figure 4);
- Nicrallium type 5 grade 23 (TA6V ELI) titanium disc 98,5x14mm (BCS Dental Alloys, Chassieu, France).



Figure 4. Paragon Tools – Yenadent compatible tools

Compatible custom CAD/CAM dental implant abutment design

The design of the Bredent Sky compatible custom CAD/CAM dental implant abutment was made with Exocad DentalCAD 3.2 Elefsina software having a study model with original Bredent Sky analogue and a Yenadent scanning Abutment compatible with original Bredent Sky (Figure 5).

hyperDENT CAM software and Paragon Tools

The CAM hyperDENT software is one of the best profile software because it managed to effectively integrate the milling cycles from the industrial segment in the dental field [15]. Regardless of the type of milling machines on the market, hyperDENT manages to

successfully optimize the parameters of milling strategies regardless of the material used by each dental laboratory, but especially metal alloys, offering the possibility of milling dental implant connections in disc (Figure 6).

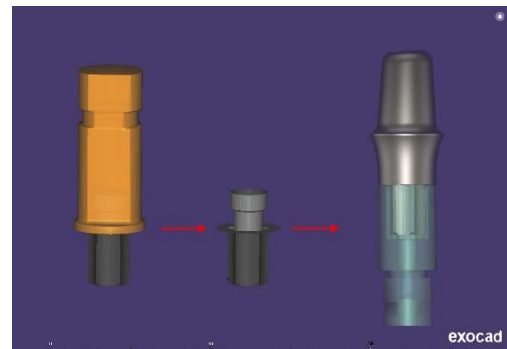

Figure 5. Design of Bredent Sky compatible custom CAD/CAM dental implant abutment

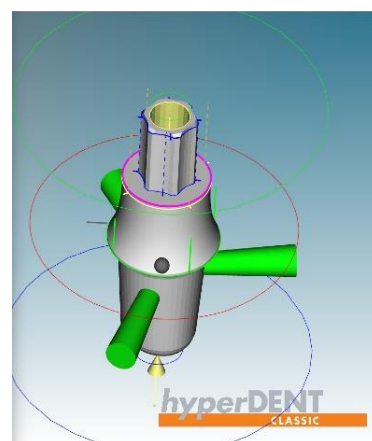

Figure 6. Defining categories for milling dental implant connection

To be able to mill the most common connections of implant systems on the market,

we have chosen the compatible Yenadent D43 milling machine tools from Paragon Tools. According to the manufacturer, these tools are the result of a collaboration between experienced turning tools design engineers, CAD/CAM milling specialists and tools plating experts, managing to have particularly good machining of complex titanium alloys with high wear resistance and oxidation [16]. For this study, the following types of tools are used for milling the Bredent Sky connection: 4 Spherical tools with a diameter of 3 mm, 2 mm, 1.5 mm and 1 mm for the general roughing stages, for finishing from the two occlusal and cavity directions, as well as finishing the emergence profile, 2 Toric tools and 2 Flat tools for milling the screw channel and the implant interface.

Nikon stereomicroscope SMZ745T

The micro-gaps evaluation of the studied dental implant original and non-original abutments was performed by microscopic analysis using the Nikon SMZ745T stereomicroscope (Figure 7), recommended for both industrial and biomedical applications. It has a magnification of 75X and a working distance of 115 mm, which allows optimal visualization of processing traces on study samples. Real Time EDF (Extended Depth of Field) was used to capture high-resolution images.



Figure 7. Nikon stereomicroscope SMZ745T

The dental implant abutments from the 4 lots were prepared for analysis and

measurement of the micro-gaps between abutment and implant by dividing each into four different faces A, B, C and D, to be able to establish an identical analysis rule for each. In order to record the data obtained as closely as possible to the dental understanding, we determined that Face A represents the Vestibular (Buccal) face of the abutment, Face B represents the Distal face of the abutment, Face C represents the Palatal face of the abutment and Face D represents the Mesial face of the abutment. We also determined that three measurements should be made on each face, one in the middle of the face and two at the angle from the neighbouring faces.

Thus, the measurements were:

- Vestibular (V), Vestibulo-distal (VD) and Vestibulo-mesial (VM);
- Distal (D), Disto-vestibular (DV) and Disto-palatal (DP);
- Palatal (P), Palato-distal (PD) and Palato-mesial (PM);
- Mesial (M), Mesio-vestibular (MV) and Mesio-palatal (MP).

The Bredent Blue Sky implant was fixed in a plaster hexagon to be stable when screwing each abutment to be analysed (Figure 8).



Figure 8. The Bredent Blue Sky implant fixed in a plaster hexagon.

Each abutment was fixed by screwing with a torque wrench to 25 Nm, after that

measurements were made at each point according to the established rules (Figure 9). For each abutment, those measurements formed a series of values. The following statistical indicators were computed for each series: the minimum (Min) and maximum (Max) values, the interval between these measurements (range), the percentual difference (computed as the ratio between the difference Min-Max and the maximum measurement), the arithmetic mean of all measurements, and the variance of the entire series (defined as the degree of spreading of the values between Min and Max).

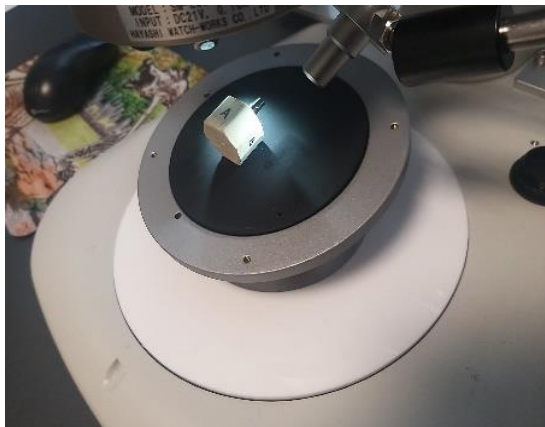

Figure 9. Micro-gaps measurement stages.

Statistical analysis

Statistical tests were performed using Statistical Package for Social Sciences (SPSS), version 26 (IBM Corp., Armonk, NY, USA) using the measurements recorded for each abutment. These variables are continuous, and they were expressed as mean \pm standard deviation (SD). Statistical analysis was based on Shapiro–Wilk’s test for data normality analysis, Levene’s test of equality of variances, and, since all series were normally distributed, one-way ANOVA for group comparisons. The value $p < 0.05$ was considered statistically significant.

RESULTS

All dental implant abutments from the four lots were observed under the microscope at 45x and 75x magnification and at 75x magnification, photographs were taken, and measurements were made at the three points of each face.

A one-way ANOVA was conducted to determine if the indicators computed based on the measurements between abutments and implant, were different within the study groups. There were no outliers, as assessed by a boxplot; data was normally distributed for each group, as assessed by Shapiro-Wilk test ($p > 0.05$), and there was homogeneity of variances, as assessed by Levene's test of homogeneity of variances ($p > 0.05$).

The smallest average minimum distance measured between implant and abutment was recorded for abutments included in the custom CAD/CAM groups, unchanged compatible and modified compatible, in this order, followed by Exso and Compatible groups; the differences between these groups were statistically significant (Table 1).

The largest average maximum distance measured between implant and abutment was recorded for abutments included in the “Compatible” group, followed closely by the “Modified compatible custom CAD/CAM” group. The “Unchanged compatible custom CAD/CAM” group exhibited the smallest values, still the differences between groups were not statistically significant. Similar results were obtained for interval lengths, percentual differences and variances, with a different order for each variable, and no statistically significant differences between the four abutment types (Table 1).

The “Unchanged compatible custom CAD/CAM” group had the lowest minimum and maximum measurements, being the closest to the implant. Measurements for these abutments have the smallest degree of spreading within the interval, and their means are significantly smaller than those of other groups, $p = 0.013$ (Table 1).

Variable	Exso	Compatible	Unchanged compatible custom CAD/CAM	Modified compatible custom CAD/CAM	F*	p*
Min (µm)	5.36 ± 0.58	5.83 ± 1.25	3.34 ± 0.61	4.46 ± 0.93	7.542	0.002 [#]
Max (µm)	14.34 ± 4.70	16.01 ± 1.19	10.74 ± 1.38	15.84 ± 3.66	3.070	0.058
Interval length (µm)	8.97 ± 4.39	10.18 ± 1.76	7.40 ± 1.39	11.38 ± 3.12	1.691	0.209
Percentual difference (%)	59.91 ± 10.43	63.37 ± 8.75	68.57 ± 5.79	71.42 ± 4.48	2.227	0.125
Arithmetic mean (µm)	9.18 ± 1.98	10.37 ± 0.34	6.81 ± 0.30	9.24 ± 2.23	4.918	0.013 [#]
Variance (µm)	7.81 ± 7.41	9.37 ± 3.30	4.87 ± 1.37	11.58 ± 7.07	1.323	0.302

* One-way ANOVA. # Statistically significant

Table 1. Measurements of the four study lots, mean ± SD, values expressed in µm and percentage (for Percentual difference).

The following photographs highlight several examples of micro-gaps in the three points established at the junction between the dental implant abutment and the dental implant.

The measurements of the original Bredent Sky dental implant stock abutments from Lot 1 (examples OBS1 and OBS2), are highlighted in Figure 10 and in Figure 11.

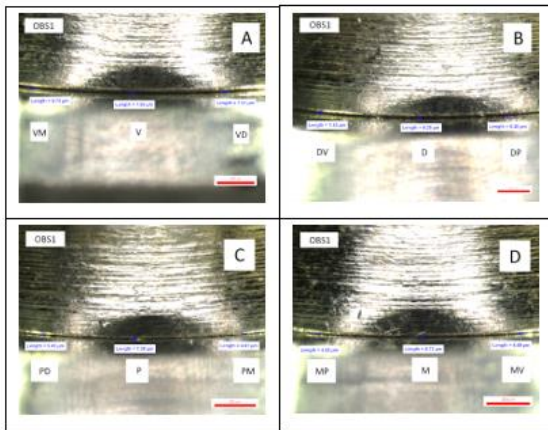

Figure 10 – Micro-gaps measured at Lot 1 OBD1 abutment.

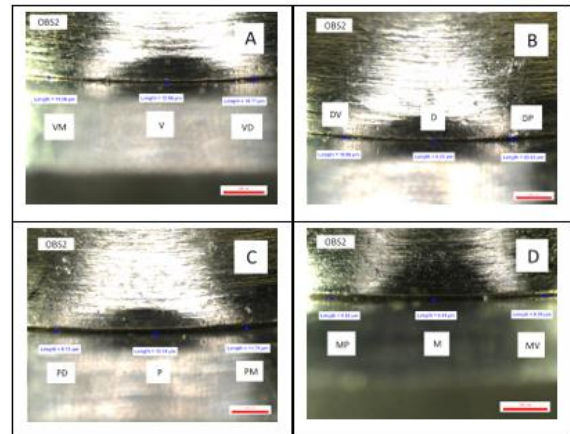

Figure 11. Micro-gaps measured at Lot 1 OBD2 abutment.

The measurements of the compatible Bredent Sky dental implant stock abutments from Lot 2 CNM1 are highlighted in Figure 12 and CNM2 in Figure 13.

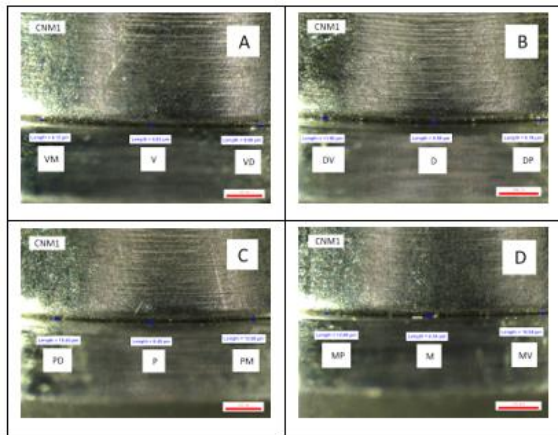

Figure 12. Micro-gaps measured at Lot 2 CNM1 abutment

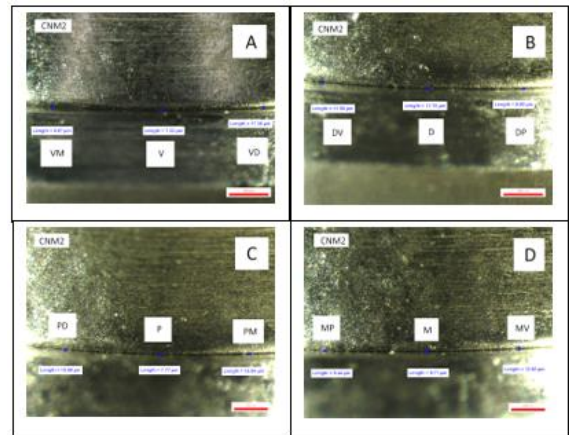

Figure 13. Micro-gaps measured at Lot 2 CNM2 abutment.

The measurements of the compatible Bredent Sky custom CAD/CAM dental implant abutments from Lot 3 CYD1 are highlighted in Figure 14 and CYD2 in Figure 15.

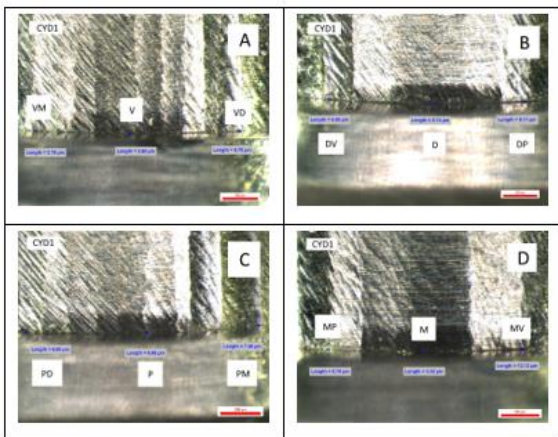

Figure 14. Micro-gaps measured at Lot 3 CYD1 abutment.

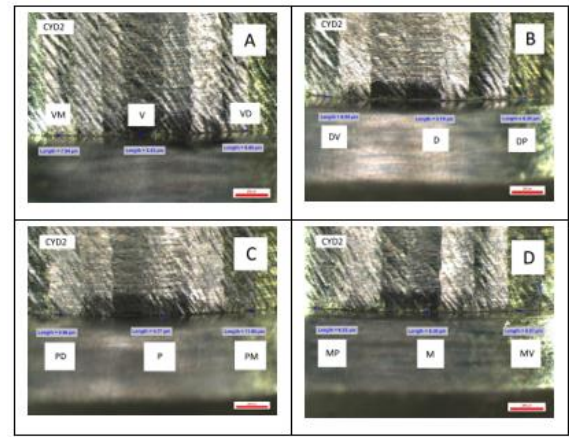

Figure 15. Micro-gaps measured at Lot 3 CYD2 abutment.

The measurements of the compatible Bredent Sky custom CAD/CAM dental implant abutments from Lot 4 CYD3 are highlighted in Figure 16 and CYD4 in Figure 17.

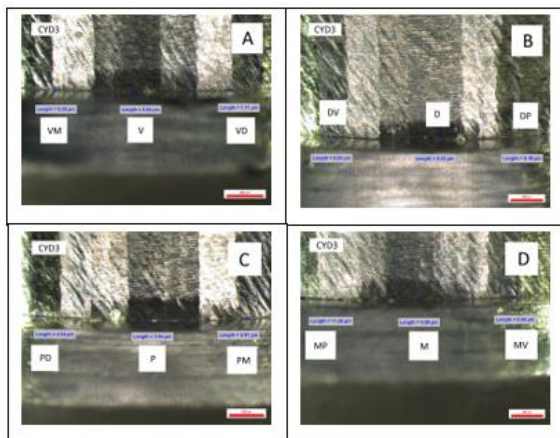

Figure 16. Micro-gaps measured at Lot 4 CYD3 abutment.

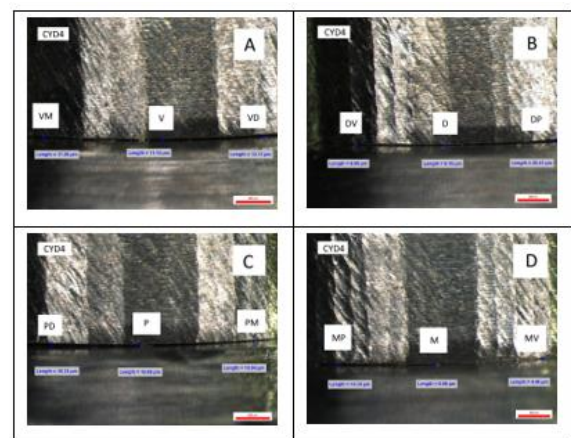

Figure 17. Micro-gaps measured at Lot 4 CYD4 abutment.

DISCUSSIONS

The aim of the present study is to evaluate the possible differences between the original, compatible and customized dental implant abutments in terms of the microscopic dimensions of the micro-gaps between abutment and the dental implant. Due to the high demand for custom dental implant abutments, various studies have appeared about the results obtained in the production of compatible dental implant abutments, with some authors claiming the superiority of the original dental implant stock abutments over custom dental implant abutments milled by independent milling centers or dental laboratories [17-23], and other authors arguing that there is no significant difference between them [24-29].

Among the studies showing that the original dental implant stock abutments are more suitable than the non-original ones is that of Gingadet M. et al. [17], that observed that a CAD/CAM compatible dental implant abutment did not have the same rotational fit as the original abutment. Also, in a study by Berberi A et al. [18] with simulated clinical loading conditions, the authors observed that compatible dental implant stock abutments

showed greater micro-movement than the original dental implant abutments. Cashman P.M. et al. [19] observed in their study obvious macro and microscopic visual differences in the geometric connection, the compatible dental implant stock abutments having a greater deviation than the original dental implant stock abutments. Park J.M. et al.[20], in their study comparing the loosening of one-piece interchangeable abutments to an internally connected implant, observed a much higher removal torque of the original abutment than the compatible abutment. Kim E.S. et al. [21] and Attiah EMN et al. [22] observed that the initial loosening of the screw was clearly influenced by compatible customized CAD/CAM and compatible stock abutments as opposed to the original stock abutments. In another study, the authors Yilmaz B. et al. [23] were very categorical in their analysis of the load-to-failure performance of the original and non-original abutments, concluding that the original abutments suffered no fracture compared to the non-original abutments which had screw fracture.

However, there are also authors who consider non-original compatible CAD/CAM

milled dental implant abutments to be a good solution for implant restorations. Paek J. et al. [24], in their study on determining the stability of prefabricated and CAD/CAM abutments by measuring the removal torque before and after immediate loading, found no significant difference between stock and CAD/CAM milled abutments in terms of tightening torque initial and after removal, concluding that milling with precise CAD/CAM abutment control can achieve good screw joint stability. In another study to test maximum load capacity, Kim J.S. et al. [25] found that there were fracture differences between the abutments tested, but the customized CAD/CAM dental implant abutments had a much higher load capacity than the original dental implant stock abutments. In another study, Alonso-Pérez R. et al. [26] found no significant differences between the original dental implant stock abutments and the non-original custom dental implant abutments produced by laser sintering in the process of mechanical testing of static and dynamic loading, although a better adaptation of the original abutments than the non-original ones to the implant was observed. In another study looking at the assessment of CAD/CAM abutment fit to the implant compared to one manufacturer's proprietary prefabricated abutments, Hamilton A. et al. [27] concluded that CAD/CAM abutments appear to have a fit comparable to prefabricated abutments for most of the systems evaluated, except for one implant system where design differences between the abutment connections were observed that affected the fit of the internal components of the implant-abutment connections.

Another assessment of a possible vertical mismatch between different dental implants and non-original compatible stock abutments was made by Sola-Ruiz M.-F. et al. [28] by analyzing the images with the NIS-Elements software. They concluded that there was compatibility between the dental implants and non-original compatible stock abutments, the vertical adaptations obtained were within the limits considered clinically acceptable [28,29].

The results of the present study, with all existing limitations, show us that compatible customized CAD/CAM dental implant abutments provide similar results in terms of micro-gaps at the abutment-implant level, if not sometimes even better compared to the original dental implant stock abutments or compatible dental implant stock abutments. The existence of this smaller or larger micro-gaps is evident when we talk about connecting two components: implant and prosthetic abutment, a major role being represented by dimensional tolerances and permissible limits of variation of a physical dimension that deviates from a nominal size [30]. If at the industrial level the high-quality manufacture of components with precise adaptations is given by quality controls, at the dental laboratory level there are limits regarding the milling of customized CAD/CAM abutments. These limits can be exceeded if software and tools are used that offer the possibility of producing components that are within the permissible limits of deviation from the nominal size.

Although in this study we did not make any changes to the dimensions of the abutments milled by us, the hyperDENT software offers a function to set the tolerances of the connection to obtain a more fixed adaptation to the dental implant. It can result a smaller micro-gap or no gap, but the modification of tolerances in the manufacture of CAD/CAM compatible dental implant abutments will be the subject of a future study.

CONCLUSIONS

Within the limits of this *in vitro* study, we can conclude that all measurements performed on compatible CAD/CAM dental implant abutments are like original dental implant stock abutments and compatible dental implant stock abutments.

The null hypothesis of this study was validated because our study revealed that there is no statistically significant difference of micro-gaps between compatible CAD/CAM dental implant abutments and original dental implant stock abutments and compatible dental implant stock abutments,

and the values of the assessed micro-gaps are within the clinically accepted limit.

With proper quality control and the possibility of modifying milling parameters in the hyperDENT CAM software and using suitable milling tools, in our case Paragon Tools, CAD/CAM compatible abutments could offer a very good adaptation and a lower value of the micro-gaps between implant and abutment, sometimes even with better values than dental implant stock abutments.

Authors' contributions

All authors read and approved the final manuscript. All authors have equally contributed to this work.

Ethical statement

Written informed consent was not applicable for this study. The study has the approval of the Ethics Committee of University of Medicine and Pharmacy of Craiova (No. 210/10.11.2022).

Conflict of interest statement

The authors declare no conflict of interest concerning this study.

Acknowledgments

The authors would like to thank to Arnaldo Freddi Managing Director at Follow-Me Technology Group South-East Europe and Isaac Ciurana General Manager at Paragon Tools for their support.

Funding information

This research received no specific grant from any funding agency.

REFERENCES

1. Steinebrunner L., Wolfart S., Ludwig K., Kern M. "Implant-abutment interface design affects fatigue and fracture strength of implants". *Clin Oral Implants Res.* 2008 Dec;19(12):1276-84.
2. Bozkaya D., Müftü S. "Mechanics of the tapered interference fit in dental implants". *J Biomech.* 2003 Nov;36(11):1649-58.
3. Karl M., Taylor T.D., "Parameters determining micromotion at the implant-abutment interface". *Int J Oral Maxillofac Implants.* 2014 Nov-Dec;29(6):1338-47.
4. Ahmed S.E., Kalaighan P., Mohan J. "Evaluation of Microgap at the Implant-Abutment Interface with Premachined and Custom Cast Implant Abutments – An in vitro Study". *J Adv Med Dent Scie Res* 2019;7(11):23-32.
5. Meleo D., Baggi L., Girolamo M.D., Carlo F.D., Pecci R., Bedini R. "Fixture-abutment connection surface and microgap measurements by 3D micro-tomographic technique analysis". *Ann Ist Super Sanita.* 2012;48(1):53-58
6. Hamilton A., Judge R.B., Palamara J.E., Evans C. "Evaluation of the fit of CAD/CAM abutments". *Int J Prosthodont.* 2013;26(4):370-380
7. Scarano A., Mortellaro C., Mavriqi L., Pecci R., & Valbonetti L. (2016). "Evaluation of Microgap With Three-Dimensional X-Ray Microtomography: Internal Hexagon Versus Cone Morse". *J Craniofac Surg,* 27(3), 682-685.
8. Alves D. C., de Carvalho P. S., Elias C. N., Vedovatto E., & Martinez E. F. (2016). "In vitro analysis of the microbiological sealing of tapered implants after mechanical cycling". *Clin Oral Investig,* 20(9), 2437-2445.
9. Hernigou P., Queinnec S., & Flouzat Lachaniette C. H. (2013). "One hundred and fifty years of history of the Morse taper: from Stephen A. Morse in 1864 to complications related to modularity in hip arthroplasty". *Int Orthop,* 37(10), 2081-2088.
10. Vigolo P., Fonzi F., Majzoub Z., & Cordioli G. (2006). "An in vitro evaluation of titanium, zirconia, and alumina procerab abutments with hexagonal connection". *Int J Oral Maxillofac Implants,* 21(4), 575-580.
11. Vinhas A.S., Salazar F., Mendes J.M., Silva A.S., Ríos-Carrasco B., Ríos-Santos J.V., Gil J., Herrero-Climent M., & Aroso C. (2024). SEM Analysis and Micro-CT Evaluation of Four

- Dental Implants after Three Different Mechanical Requests-In Vitro Study. *Materials* (Basel, Switzerland), 17(2), 434. <https://doi.org/10.3390/ma17020434>
12. Nascimento C., Pita M.S., Santos Ede S., Monesi N., Pedrazzi V., Albuquerque Junior R.F., et al. (2016). "Microbiome of titanium and zirconia dental implants abutments". *Dent Mater*, 32(1), 93-101.
 13. Ericsson I., Persson L.G., Berglundh T., Marinello C.P., Lindhe J., & Klinge B. (1995). "Different types of inflammatory reactions in peri-implant soft tissues". *J Clin Periodontol*, 22(3), 255-261.
 14. Siar C.H., Toh C.G., Romanos G., Swaminathan D., Ong A.H., Yaacob H., et al. (2003). "Peri-implant soft tissue integration of immediately loaded implants in the posterior macaque mandible: a histomorphometric study". *J Periodontol*, 74(5), 571-578
 15. <https://www.follow-me-tech.com/hyperdent/>
 16. https://landings.paragon.tools/paragon_tools
 17. Gigandet M., Bigolin G., Faoro F., Bürgin W., Brägger U. "Implants with original and non-original abutment connections". *Clin Implant Dent Relat Res*. 2014 Apr;16(2):303-11.
 18. Berberi A., Maroun D., Kanj W., Amine E.Z., Philippe A. "Micromovement Evaluation of Original and Compatible Abutments at the Implant-abutment Interface". *J Contemp Dent Pract*. 2016 Nov 1;17(11):907-913.
 19. Cashman P.M., Schneider R.L., Schneider G.B., Stanford C.M., Clancy J.M., Qian F. "In vitro analysis of post-fatigue reverse-torque values at the dental abutment/implant interface for a unitarian abutment design". *J Prosthodont*. 2011 Oct;20(7):503-9.
 20. Park J.M., Baek C.H., Heo S.J., Kim S.K., Koak J.Y., Kim S.K., Belser U.C. "An In Vitro Evaluation of the Loosening of Different Interchangeable Abutments in Internal-Connection-Type Implants". *Int J Oral Maxillofac Implants*. 2017 Mar/Apr;32(2):350-355.
 21. Kim E.S., Shin S.Y. "Influence of the implant abutment types and the dynamic loading on initial screw loosening". *J Adv Prosthodont*. 2013 Feb;5(1):21-8.
 22. Attiah E.M.N., AlGendy A.A., Mostafa T.M.N. "Effect of dynamic cyclic loading on screw loosening of retightened versus new abutment screw in both narrow and standard implants (in-vitro study)". *Int J Implant Dent*. 2020 Jul 28;6(1):30.
 23. Yilmaz B., Salaita L.G., Seidt J.D., Clelland N.L., McGlumphy E.A. "Load to failure of different titanium abutments for an internal hexagon implant". *J Prosthet Dent*. 2015 Oct;114(4):513-6.
 24. Paek Janghyun & Woo, Yi-Hyung & Kim, Hyeong-Seob & Pae, Ahran & Noh, Kwantae & Lee, Hyeonjong & Kwon, Kung-Rock, "Comparative Analysis of Screw Loosening With Prefabricated Abutments and Customized CAD/CAM Abutments," *Implant Dentistry*, vol. 25, no. 6, pp. 770–774, 2016.
 25. Kim J.S., Raigrodski A.J., Flinn B.D., Rubenstein J.E., Chung K.H., Mancl L.A. "In vitro assessment of three types of zirconia implant abutments under static load". *J Prosthet Dent*. 2013 Apr;109(4):255-63.
 26. Alonso-Pérez R., Bartolomé J.F., Ferreira A., Salido M.P., Pradies G. "Evaluation of the Mechanical Behavior and Marginal Accuracy of Stock and Laser-Sintered Implant Abutments". *Int J Prosthodont*. 2017 Mar/Apr;30(2):136-138.
 27. Hamilton A., Judge R.B., Palamara J.E., Evans C. "Evaluation of the fit of CAD/CAM abutments". *Int J Prosthodont*. 2013 Jul-Aug;26(4):370-80.
 28. Solá-Ruiz M.F., Selva-Otaola E., Senent-Vicente G., González-de-Cossio I., Amigó-Borrás V. "Accuracy combining different brands of implants and abutments". *Med Oral Patol Oral Cir Bucal*. 2013 Mar 1;18(2):e332-6.
 29. Lang L.A., Sierralta M., Hoffensperger M., Wang R.F. "Evaluation of the precision of fit between the Procera custom abutment and various implant systems". *Int J Oral Maxillofac Implants*. 2003 Sep-Oct;18(5):652-8.
 30. Tallarico M., Fiorellini J., Nakajima Y., Omori Y., Takahisa I., Canullo L. "Mechanical Outcomes, Microleakage, and Marginal Accuracy at the Implant-Abutment Interface of

Original versus Nonoriginal Implant Abutments: A Systematic Review of In Vitro Studies”.
Biomed Res Int. 2018 Dec 30;2018:2958982.